

SYSTEM STRUCTURE

MIGUTAN expansion joint covers

- 1 = Aluminium sub-structure
- 2 = Installation spacer
- 3 = MIGUFLEX-AAS sheet
- 4 = MIGUFLEX seal insert
- 5 = Stainless steel cover caps
- 6 = Stainless steel cross-headed screws
- 7 = Nylon seal
- 8 = Strip
- 9 = Load-bearing surface
- 10 = Pressure-bearing and shrinkage-free cement (e.g. epoxy resin or PCC cement)
- 11 = Connection joint cut-out expansion joint cover AAP

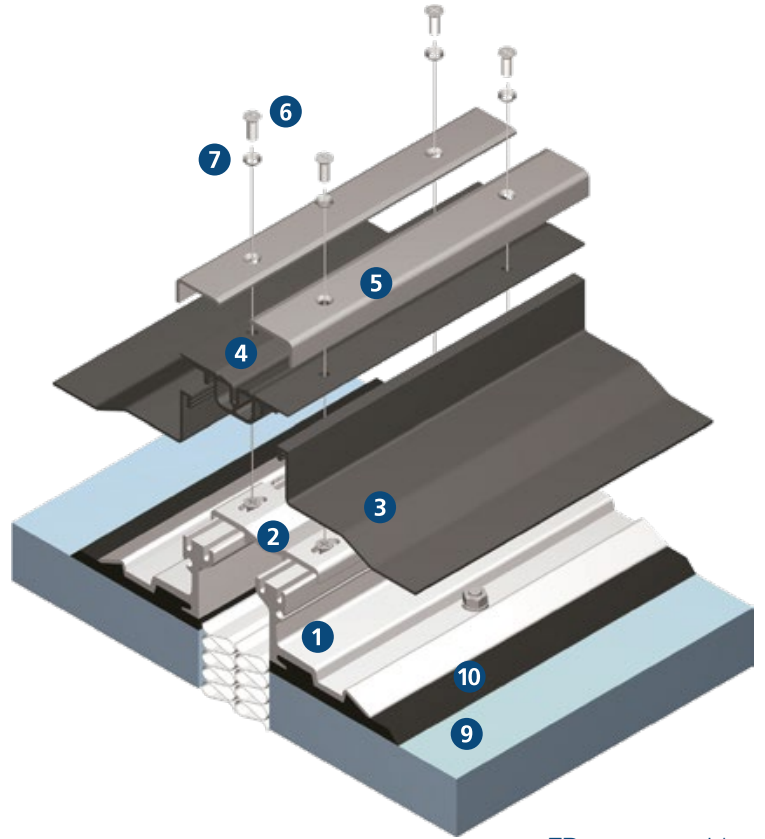

FP systems with long AAS sheets

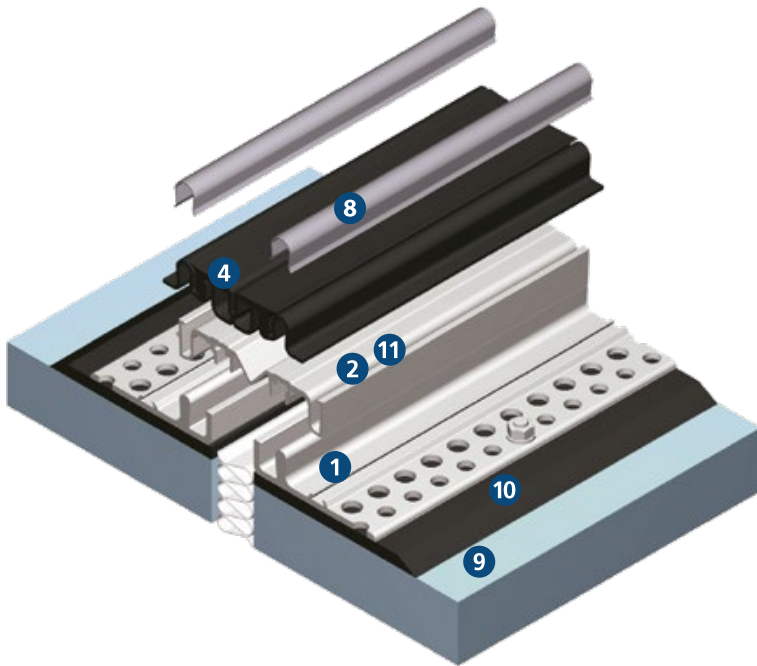

FPL systems

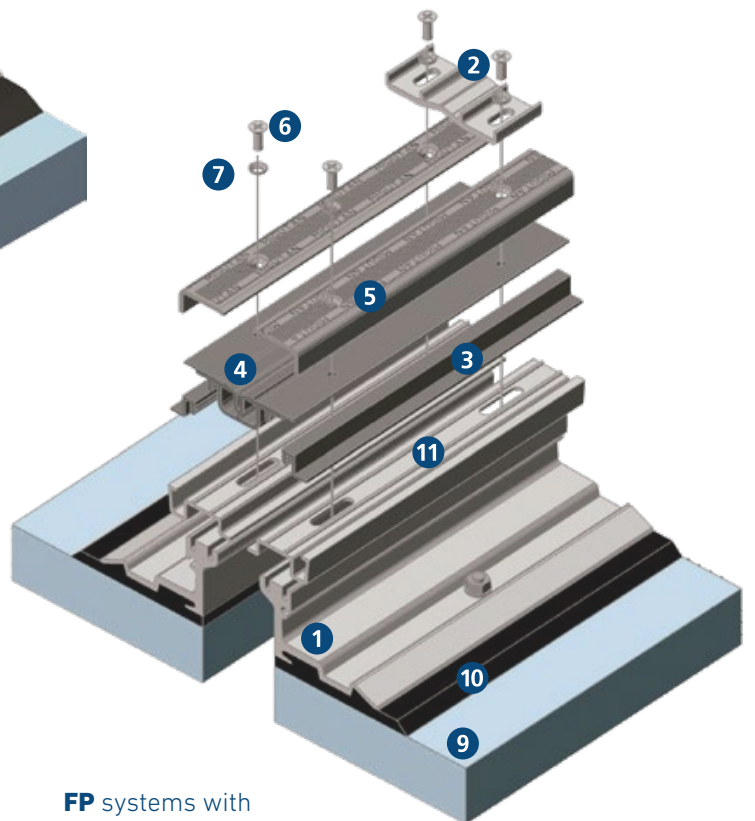

FP systems with short AAS sheets