

# MIGUTAN

DES SYSTÈMES IMPERMÉABLES À L'EAU  
DE JOINT DE DILATATION POUR LE TRAFIC

## PIÈCES MOULÉES

A 1

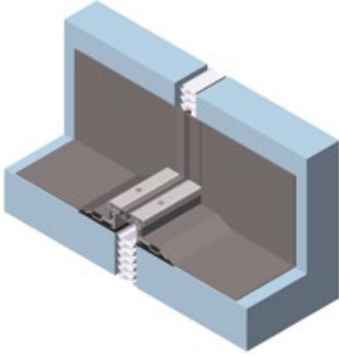

A 2

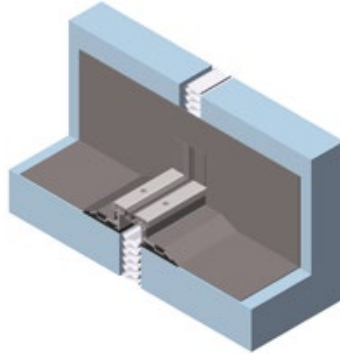

B

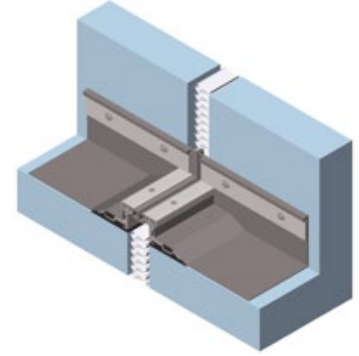

C à droite

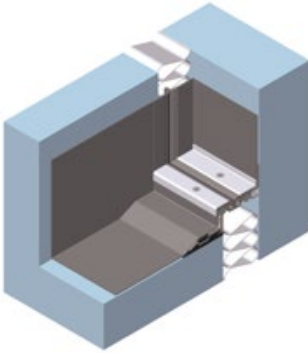

C à gauche

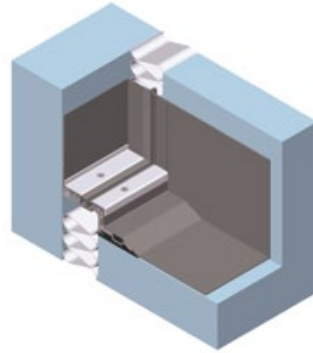

D à droite

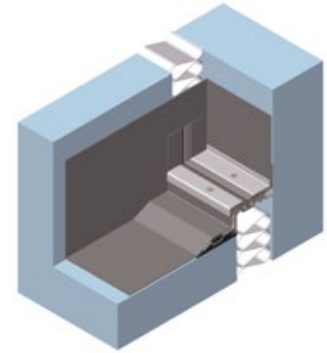

D à gauche

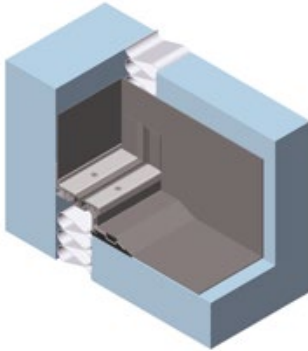

E à droite

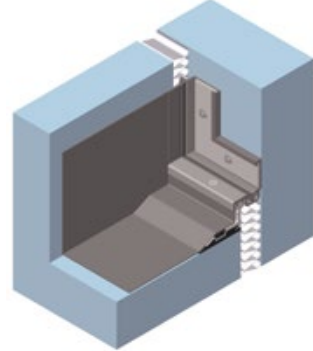

E à gauche

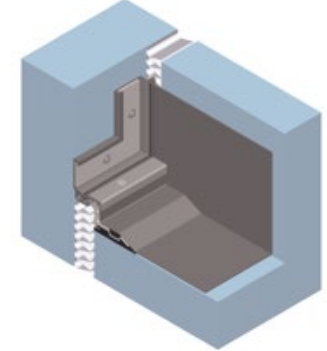

F à droite

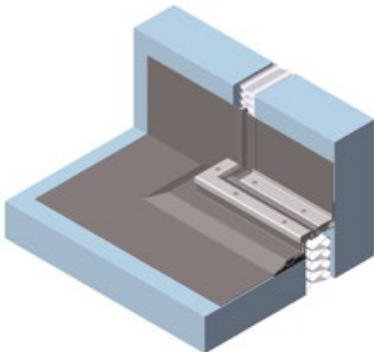

F à gauche

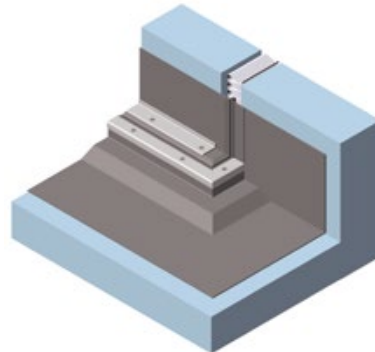

G 1

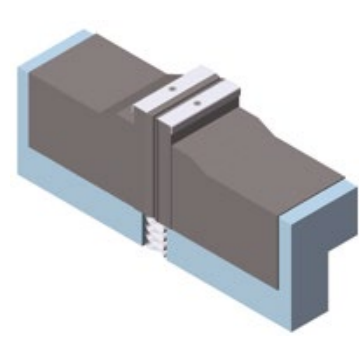

## PIÈCES MOULÉES

G 2

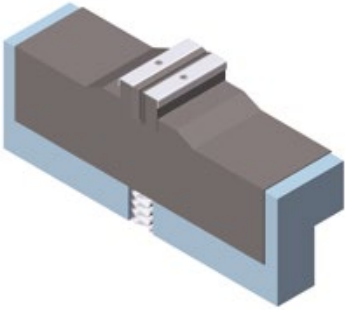

H 1 à droite

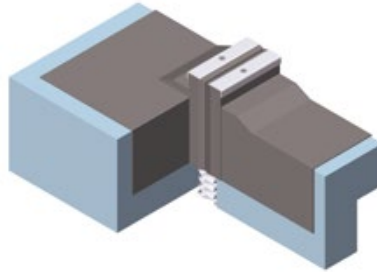

H 1 à gauche

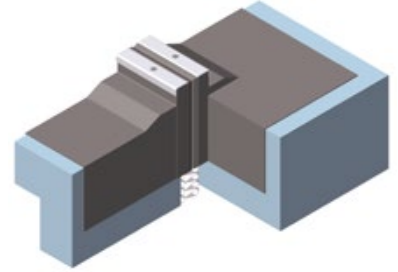

H 2 à droite

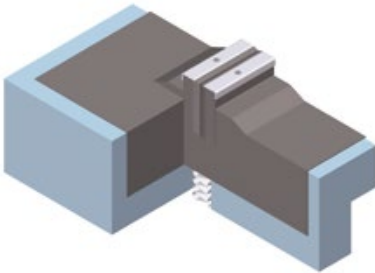

H 2 à gauche

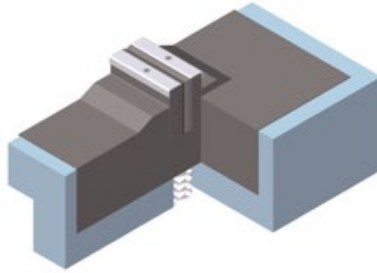

I 1 à droite

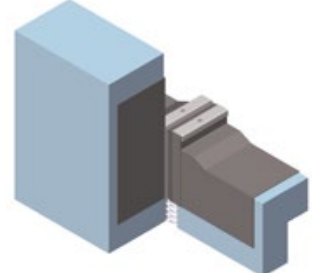

I 1 à gauche

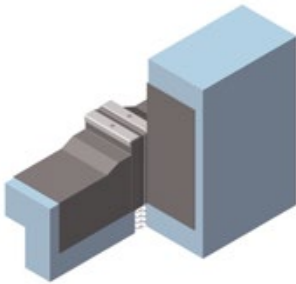

I 2 à droite

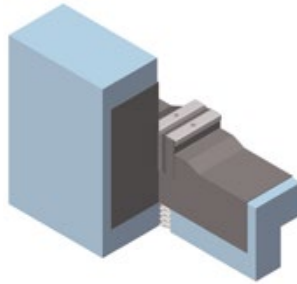

I 2 à gauche

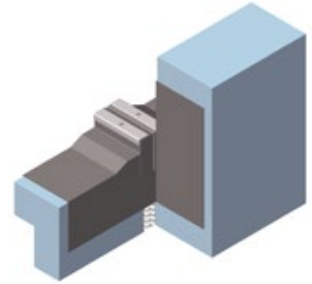

J 1 à droite

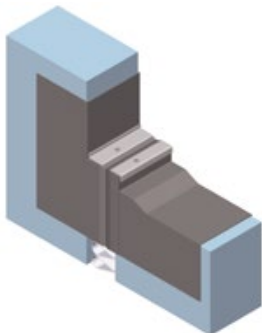

J 1 à gauche

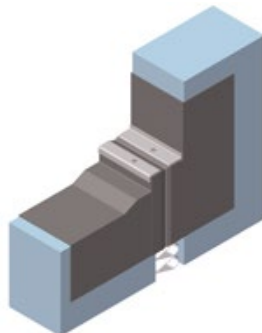

J 2 à droite

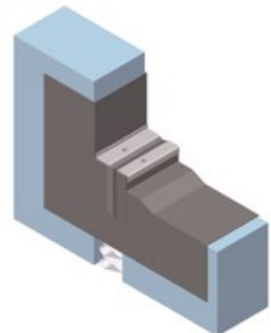

## PIÈCES MOULÉES

J 2 à gauche

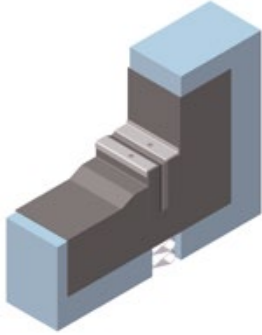

K 1 à droite

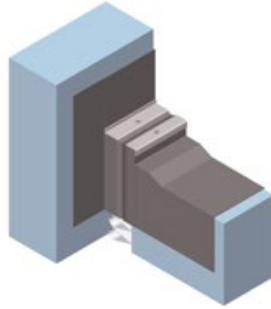

K 1 à gauche

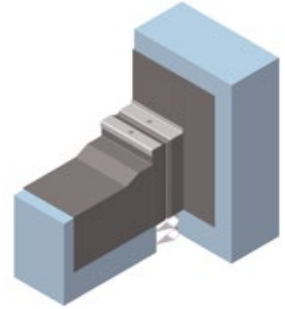

K 2 à droite

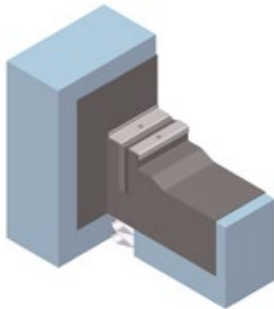

K 2 à gauche

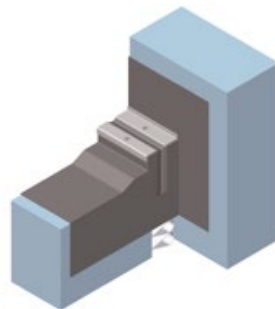

L à droite

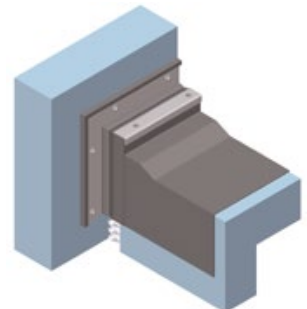

L à gauche

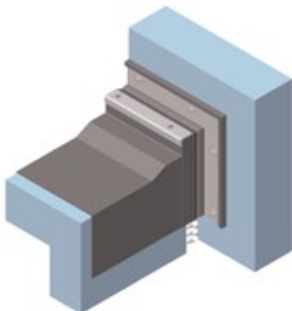

M

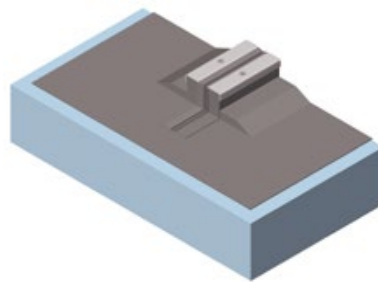

N à droite

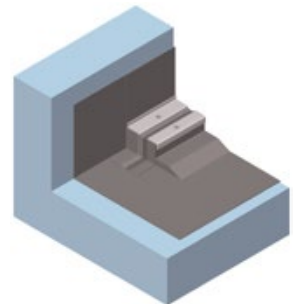

N à gauche

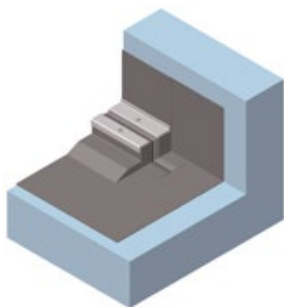

O à droite

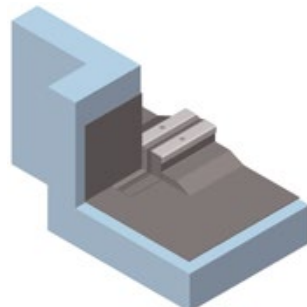

O à gauche

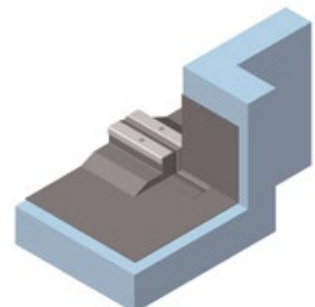

## PIÈCES MOULÉES

P à droite  
(pièce d'angle  
non fournie)

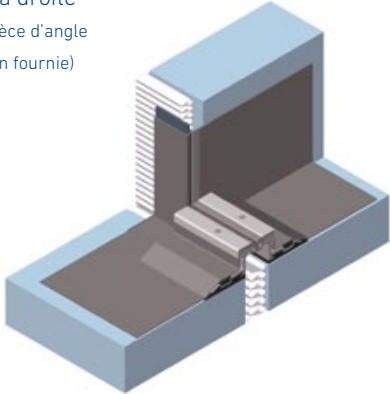

P à gauche  
(pièce d'angle  
non fournie)

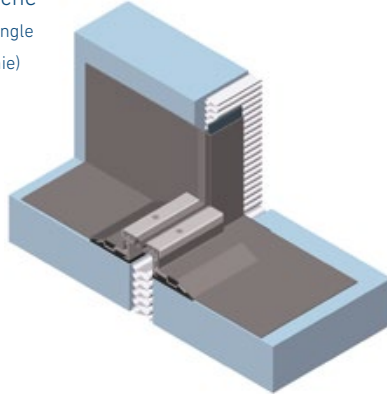

P 1 à droite  
(pièce d'angle  
non fournie)

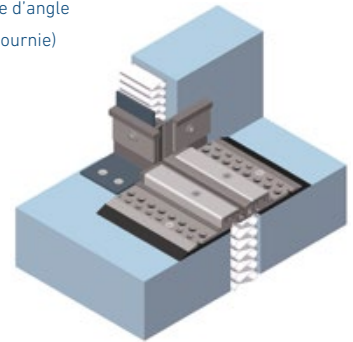

P 1 à gauche  
(pièce d'angle  
non fournie)

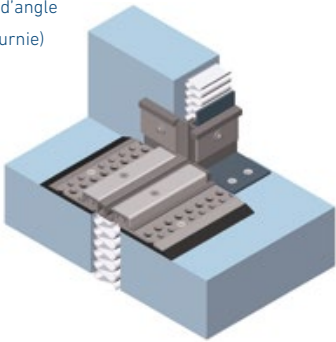

Q à droite

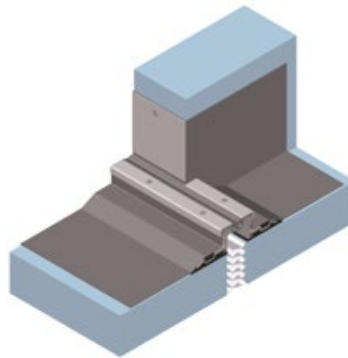

Q à gauche

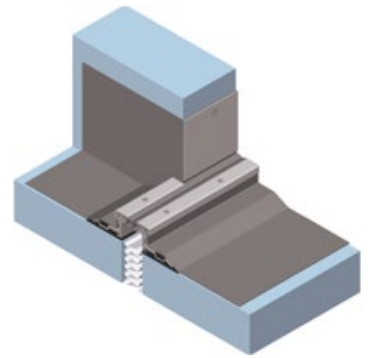

R

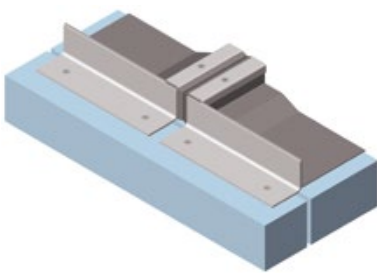

S

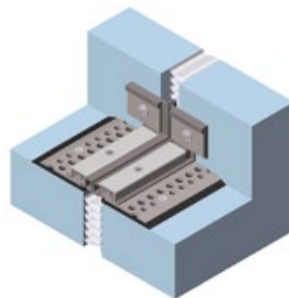

T à droite

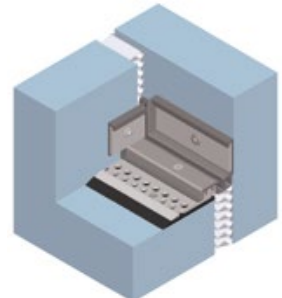

T à gauche



U

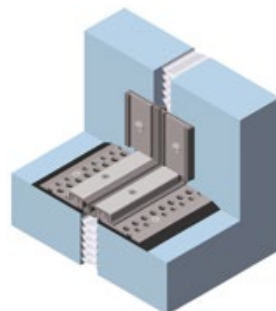

U 1

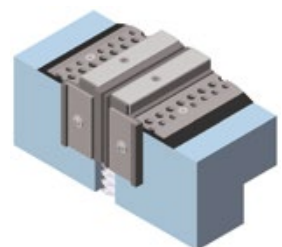

# MIGUTAN

DES SYSTÈMES IMPERMÉABLES À L'EAU  
DE JOINT DE DILATATION POUR LE TRAFIC

## PIÈCES MOULÉES

V à droite



V à gauche

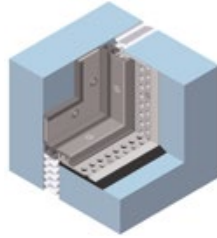

W à droite

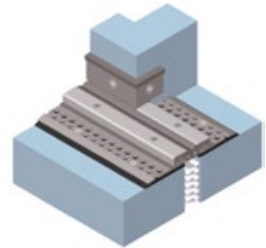

W à gauche

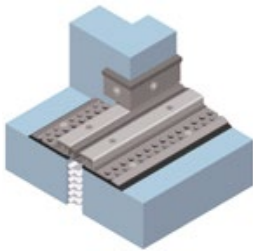

W 1 à droite

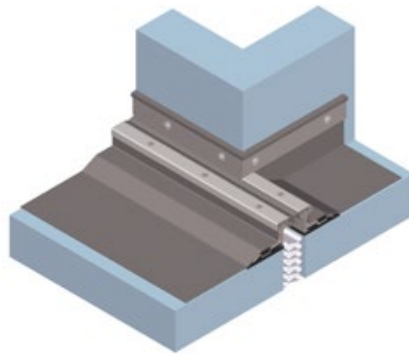

W 1 à gauche

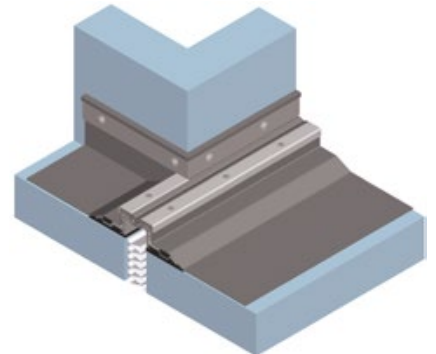

W 2 à droite

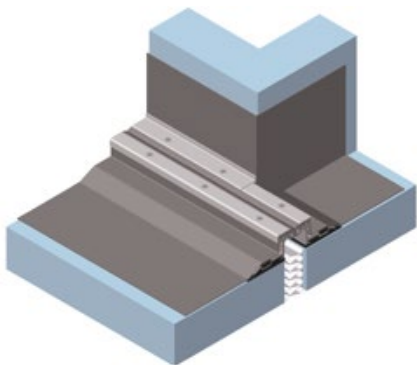

W 2 à gauche

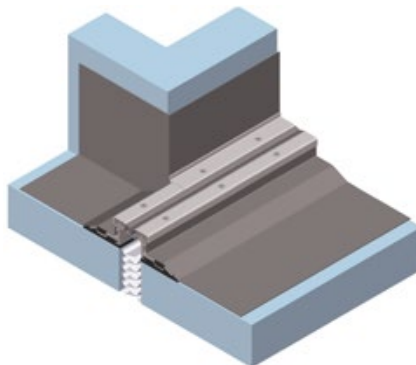

W 3 à droite

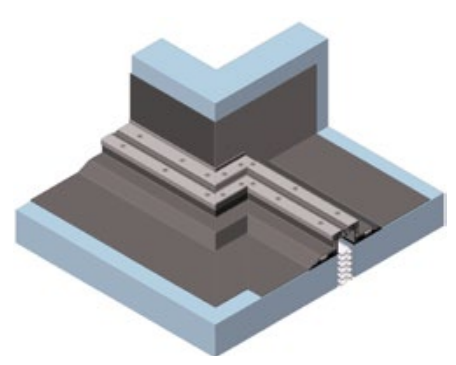

W 3 à gauche

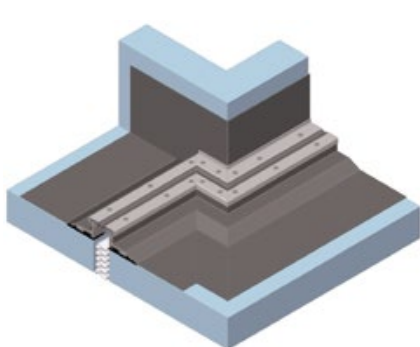

X à droite

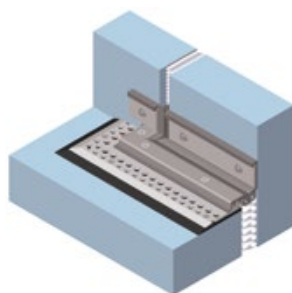

X à gauche

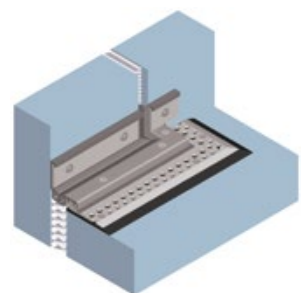

# MIGUTAN

DES SYSTÈMES IMPERMÉABLES À L'EAU  
DE JOINT DE DILATATION POUR LE TRAFIC

## PIÈCES MOULÉES

X 1 à droite

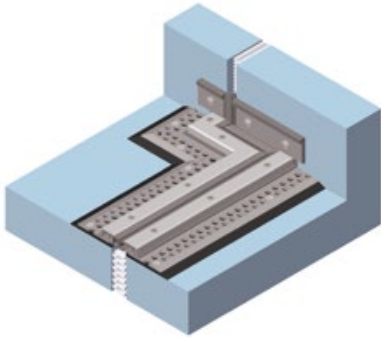

X 1 à gauche

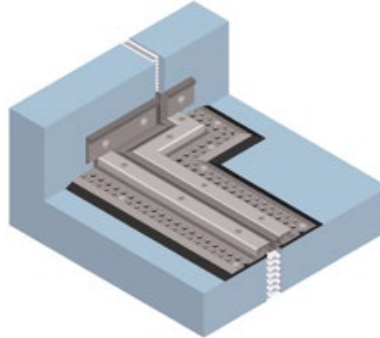

Y

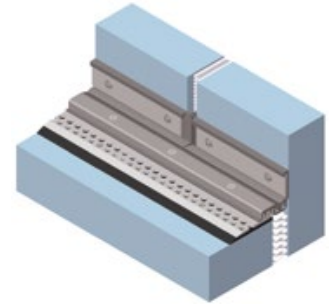

Z

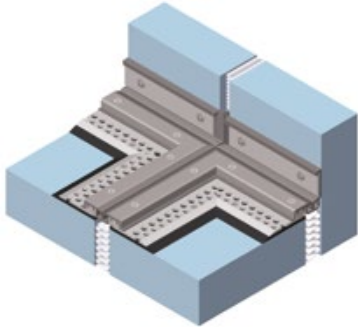

Les pièces moulées représentées A-Z présentent une gamme de pièces moulées possibles. Nous pouvons fabriquer de façon étanche tout type de pièces moulées, y compris selon la ligne de joint la plus complexe.

## PIÈCES MOULÉES STANDARD

Angle plat KF

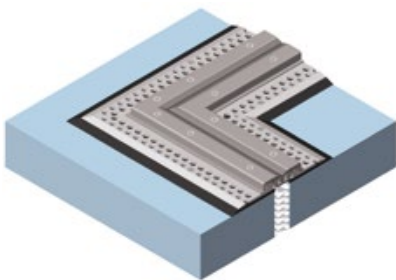

Pièce T IF

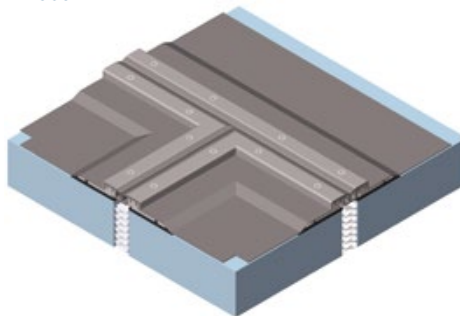

Croix KF

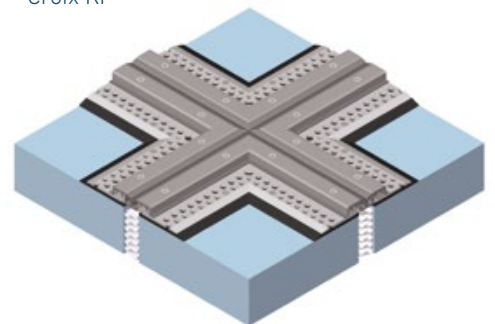

Rebord KF

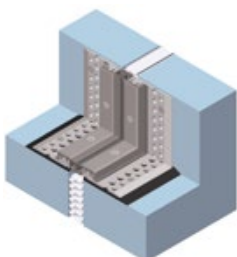

Rebord IF

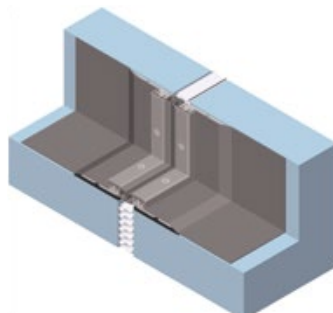

Point final de déclivité

