

**Structural stainless steel cover plate with appealing visual appearance**

good skid resistance acc. to official test certificate

**Surface for special requirements**

Caroplan, Oval-Matt, Sand, Cross hatch

**Mounting brackets are made of high strength aluminium**

High loads without any risk of rust

**Massive stainless steel caps**

Absolute tightness by maximum contact pressure

Expansion joint cover	Joint width max.		Total movement
	$b_f$ max [mm]		$\Delta b_f$ [mm]
FP 80/... NI APF		45	20 ( $\pm 10$ )
FPG 80/... NI APF		45	16 ( $\pm 8$ )
FP 90/.. NI APF		60	40 ( $\pm 20$ )
FPG 90/... NI APF		60	20 ( $\pm 10$ )
FP 110/... NI APF		75	60 ( $\pm 30$ )
FPG 110/... NI APF		75	40 ( $\pm 20$ )
FP 130/... NI APF		100	90 ( $\pm 45$ )
FP 155/... NI APF		120	120 ( $\pm 65$ )

For widths and heights as well as load capacity of the expansion joint cover, please refer to the corresponding technical data sheets of the very joint.

Available in different, officially tested anti-slip categories.

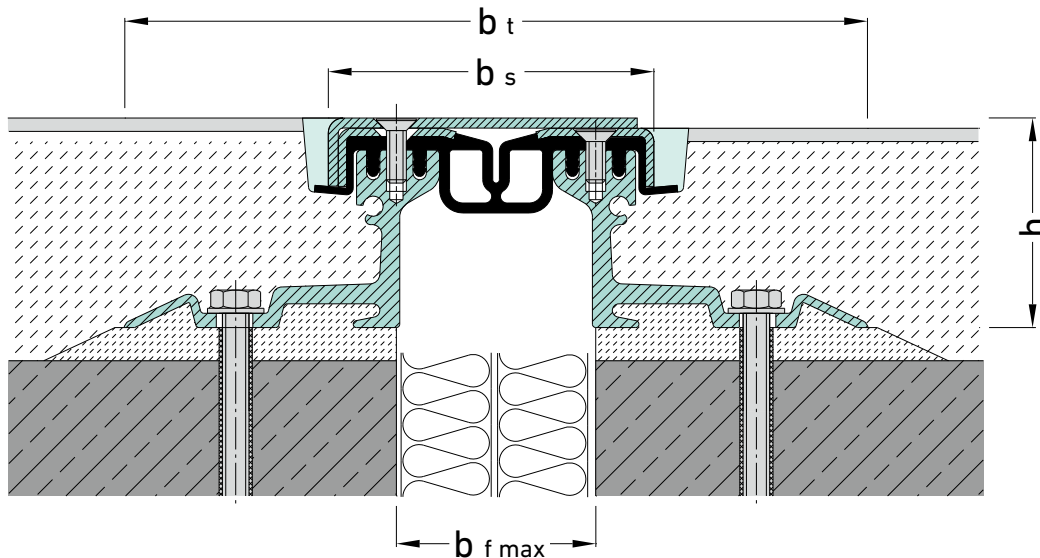

FP90/ 45NI KF APG