

FL 21

FOR FLOORS AND WALLS.

MIGUTEK

JOINT COVERS FOR EXPANSION JOINTS

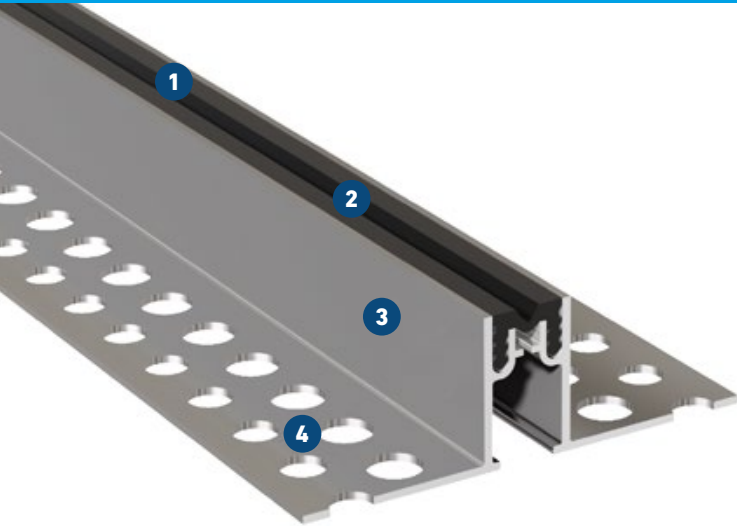

- 1 Flexible high quality elastomeric insert**
Hard wearing, temperature resistant (-30°C to +120°C), replaceable
- 2 Multi directional movement**
- 3 Quick and easy installation**
Solid, but light aluminium brackets for quick installation in screed or tiled floorings
- 4 MultiHole mounting bracket**
for secure fixing

Expansion joint cover	Joint width	Total movement	Visible width	Total width	Joint height	Load bearing capacity*  [kN]
	$b_f \text{ max}$ [mm]	Δb_f [mm]	b_s [mm]	b_t [mm]	h [mm]	
FL 21/20	20	5 (+3/-2)	21	80	20	30
FL 21/35	20	5 (+3/-2)	21	107	35	30
FL 21/50	20	5 (+3/-2)	21	107	50	30

* no continuous use

All information on load bearing capacity does only apply to non-floating floors.

For installation in asphalt, please ask for our technical advice.

The expansion joint cover with the height of 20 mm has larger punched holes and is not suitable for dowelling.

Production length: 4 m

Standard colours: black, grey

Wall connections: E3, E4

