

FLG 21

FOR FLOORS WITH HYGIENIC REQUIREMENTS

MIGUTEC

JOINT COVERS FOR EXPANSION JOINTS

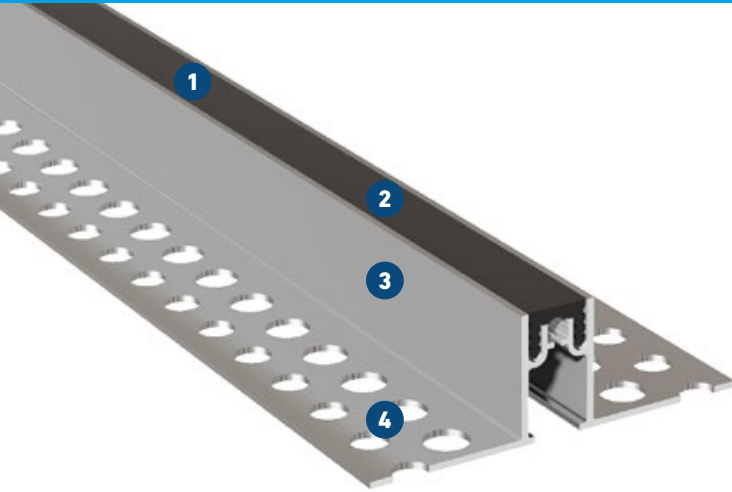

- 1 Flexible high quality elastomeric insert**
Hard wearing, temperature resistant (-30°C to +120°C), replaceable
- 2 Smooth visible surface for easy cleaning**
Antibacterial and physiologically safe
- 3 Quick and easy installation**
Solid, but light aluminium brackets for quick installation in screed or tiled floorings
- 4 MultiHole mounting bracket**
for secure fixing

Expansion joint cover	Joint width $b_f \text{ max}$ [mm]	Total movement Δb_f [mm]	Visible width b_s [mm]	Joint width total b_t [mm]	Joint height h [mm]	Load bearing capacity*  [kN]
FLG 21/20	20	2 (± 1)	21	107	20	30
FLG 21/35	20	2 (± 1)	21	111	35	30
FLG 21/50	20	2 (± 1)	21	111	50	30

* no continuous use

All information on load bearing capacity does only apply to non-floating floors.
For installation in asphalt, please ask for our technical advice.

Production length: 4 m

Standard colors: black, grey

