

ESF 10 AL

FOR CONTRACTION JOINTS IN FLOORS WITH HIGH LOAD CAPACITY

MIGUTEK

JOINT COVERS FOR EXPANSION JOINTS

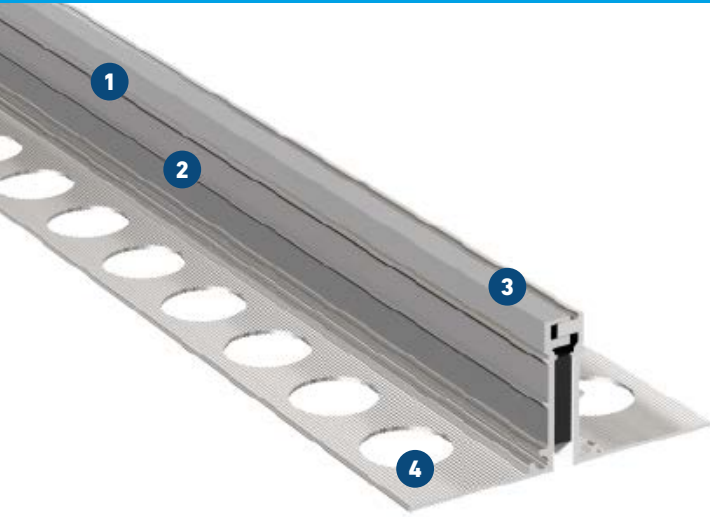

- 1 Solid all-metal expansion joint cover**
Hard wearing, maintenance free, long lasting
- 2 High load capacity**
Solid aluminium brackets, suitable for hard plastic tyres
- 3 Small visible surface**
Slim design, visible width of cover 10 mm only
- 4 MultiHole mounting bracket**
for secure fixing

NEW!

Available in smaller height 12 mm

Expansion joint cover	Joint width $b_f \text{ max}$ [mm]	Total movement Δb_f [mm]	Visible width b_s [mm]	Joint width total b_t [mm]	Joint height h [mm]	Load bearing capacity [kN]	Load bearing capacity [kN]	Load bearing capacity [kN]	Load bearing capacity solid plastic tyres [kg/mm]
ESF 10/12 AL	10	4 (± 2)	10	77	12		600	130	6,5
ESF 10/15 AL	10	4 (± 2)	10	77	15		600	130	6,5
ESF 10/17 AL	10	4 (± 2)	10	77	17		600	130	6,5
ESF 10/25 AL	10	4 (± 2)	10	77	25		600	130	6,5
ESF 10/35 AL	10	4 (± 2)	10	77	35		600	130	6,5
ESF 10/40 AL	10	4 (± 2)	10	77	40		600	130	6,5
ESF 10/50 AL	10	4 (± 2)	10	77	50		600	130	6,5
ESF 10/60 AL	10	4 (± 2)	10	77	60		600	130	6,5

All information on load bearing capacity does only apply to non-floating floors.
Larger installation heights on request.

Production length: 4 m

