

FS 99

FOR FLOORS WITH LARGE MOVEMENT – TO BE USED BY PRIVATE CARS AND PEDESTRIANS

MIGUTRANS

HEAVY-DUTY ALL-METAL JOINT SOLUTIONS FOR LARGE TRAFFIC LOADS

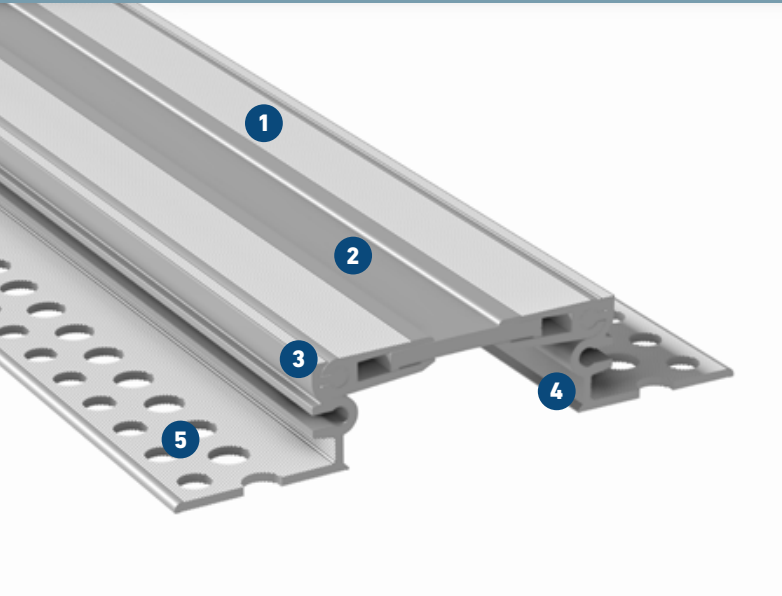

- 1 Striated surface**
ensures good skid resistance
- 2 Symmetrical visible surface shows no gaps**
avoids dirt accumulation
- 3 Articulated telescoping system**
absorbs movement in 3 directions
- 4 Solid all-metal expansion joint**
hard wearing, maintenance-free, long lasting
- 5 MultiHole mounting bracket**
for secure fixing

Expansion joint cover	Joint width max.	Total movement	Visible width	Joint width total		Joint height	Load bearing capacity
	b_f [mm]			Δb_f [mm]	b_s [mm]		
FS 99/20	70	40 (± 20)	99	186	20	12	
FS 99/35	70	40 (± 20)	99	186	35	12	
FS 99/50	70	40 (± 20)	99	186	50	12	
FS 99/90	70	40 (± 20)	99	184	90	12	

Production length: 4 m

Standard colour: Aluminium

Larger installation heights on request.

