

# FS 167

FOR HEAVY DUTY FLOORS

# MIGUTRANS

HEAVY-DUTY ALL-METAL JOINT SOLUTIONS  
FOR LARGE TRAFFIC LOADS

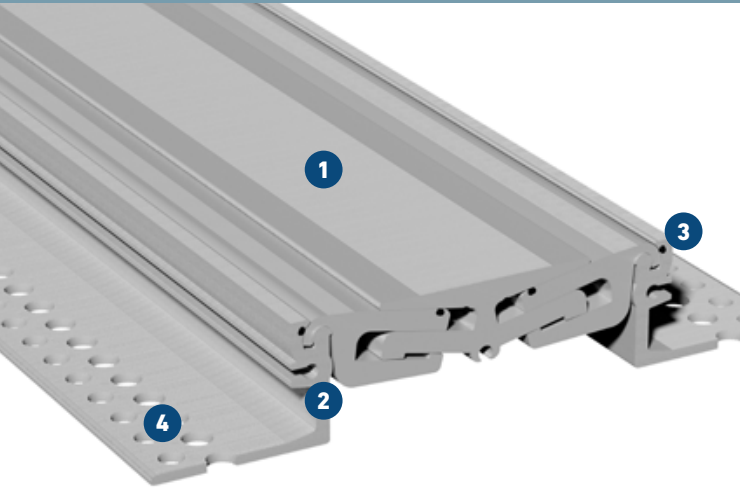

- 1** Symmetrical visible surface has no gaps  
avoids dirt accumulation
- 2** Solid all-metal expansion joint  
hard wearing, maintenance-free, long lasting
- 3** Articulated telescoping system  
absorbs movement in 3 directions
- 4** MultiHole mounting bracket  
for secure fixing

Expansion joint cover	Joint width max.	Total movement	Visible width	Total width	Joint height	Load bearing capacity  [kN]	Load bearing capacity  [kN]	Load bearing capacity  solid plastic tyres [kg/mm]
	$b_f$ [mm]	$\Delta b_f$ [mm]	$b_s$ [mm]	$b_t$ [mm]	$h$ [mm]			
FS 167/30	135	45 ( $\pm 22,5$ )	167	283	30	600	130	20
FS 167/42	135	45 ( $\pm 22,5$ )	167	283	42	600	130	20
FS 167/52	135	45 ( $\pm 22,5$ )	167	283	52	600	130	15
FS 167/62	135	45 ( $\pm 22,5$ )	167	283	62	600	130	15

**Production length:** 4 m

**Standard colour:** Aluminium

Further installation heights on request.

Required fixing distance FS 167/30: 300 mm; FS 167/42, FS 167/52 and FS 167/62

