



- 1 Solid all-metal expansion joint**
hard wearing, maintenance-free, long lasting
- 2 Visible surface has no gaps**
avoids dirt accumulation
- 3 Striated surface**
ensures good skid resistance
- 4 Articulated telescoping system**
absorbs movement in 3 directions

Expansion joint cover	Joint width min.	Total movement	Visible width	Total width	Installation height	Thickness of alu side plates	Load bearing capacity  [kN]	Load bearing capacity  [kN]	Load bearing capacity  solid plastic tyres [kg/mm]
	b_f [mm]	Δb_f [mm]	b_s [mm]	b_t [mm]	h [mm]	h_1 [mm]			
FSN 46 */**	50	20 (± 10)	286	286	21	6,6	90	70	6,5
FSNX 75	83	20 (± 10)	320	320	18	6,6	90	70	6,5
FSNX 105	111	20 (± 10)	351	351	22	6,6	90	70	6,5
FSNX 110	116	30 (± 15)	354	354	18	6,6	90	70	6,5
FSNX 130	140	40 (± 20)	378	378	27	6,6	90	35	6,5
FSNX 146	152	50 (± 25)	392	392	18	6,6	30	25	3,5
FSNX 155	162	40 (± 20)	398	398	22	6,6	90	35	6,5
FSNX 160	168	60 (± 30)	408	408	30	6,6	90	35	6,5
FSN 185 **	200	60 (± 30)	409	409	18	6,6	90	35	6,5
FSN 280 **	240	85 ($\pm 42,5$)	454	454	18	6,6	35	35	6,5
FSN 285 **	290	100 (± 50)	508	508	21	6,6	35		

* cannot take settlements

** The joint width should not differ substantially from the necessary joint width b_f .

Production length: 4 m (FSN 185, FSN 280 and FSN 285: 3 m)

Standard colour: Aluminium

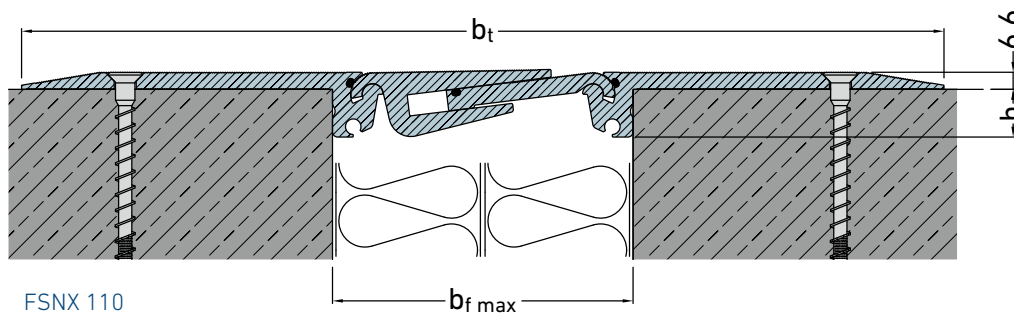

FSNX 110